

Filtration Units

FUNDABAC® | CONTIBAC® | STERIBAC®

Solid-liquid filtration solutions



DrM

www.drm.ch

FILTRATION



This is DrM

Customized solutions

Each solid-liquid separation system is tailor made to the specific application parameters of our clients. We view every application as a challenge to satisfy our clients, regardless if the application is straight forward or complex.

Application comprehension

Every solid-liquid separation application is unique. DrM's comprehension of all of the applications begins with a discussion with the client and is followed by a request that the client complete an application questionnaire to the best of its ability. Following a review of the information submitted by the client, DrM application specialists may suggest that on-site testing and/or piloting be carried out. This hands-on work ultimately gives both DrM and its clients the confidence that the process is scalable. It also puts DrM in a position to submit a technical/commercial proposal that it will stand behind.

Quality above all

DrM's Quality System is ISO 9001 certified for the design and manufacture plants. We are dedicated to continually improving the efficiency and the effectiveness of our quality management system. All of our products follow a rigid quality control program that employs the most current testing and inspection methods prior to shipment.

Meet the family

Over 40 years in the making

Filtration solutions

The FUNDABAC® Filter family comprises of a series of equipment specifically designed for the process industries, demanding high quality and productivity. It has become the industry standard for highly automated and fully enclosed operation throughout the world.



FUNDABAC® wet and dry discharge

The filtered solids are dewatered and discharged by gas blow-back. As an alternative, the cake can be reslurried into another liquid.

CONTIBAC® continuous thickening

This filter type allows continuous or semi-continuous filtration without interruption of flow. The solids are flushed back into the liquid and discharged in slurry form. This filtration process mainly applies for processes where continuous flow is required.

STERIBAC® GMP Filter

This is a variant of the FUNDABAC® design to comply with the specific production standards of pharmaceutical and biotech industries. Surface finish and design of internals allow effective cleaning of all parts in contact with product.

Filter elements

Understanding the process

Solids

During the filtration, which takes place in a pressure vessel, the liquid is pressed from the outside through the filter medium. Solids collect on its surface and form a uniform cake. The cake remains on the filter elements due to their concave-convex profile and a continually maintained pressure differential across them.

Filtrate

The filtrate flows downward through the six external filter tubes, rises inside the central tube and leaves the filter via the registers mounted in the upper portion of the pressure vessel.

Cake drying

During the pumping out of the heel volume from the filter vessel and the drying phase, gas is forced through the filter cake in the direction of the filtration towards the inside of the filter element. At the same time, the central tube guarantees that the cake on the filter element is dewatered and that the remaining liquid in the filter element is displaced by the gas without any trace of liquid remaining.

Cake discharge

After emptying the filter vessel, and possible cake washing and drying, each filter element is subjected to a reverse gas flow pressure shock. As the filter medium expands, vertical cracks are generated in the cake. When the medium reaches its maximum deflection, its movement stops and the cake is thrown off. Filter cakes of 3 to 50 mm thickness are completely discharged.

Discharge of the filter cake

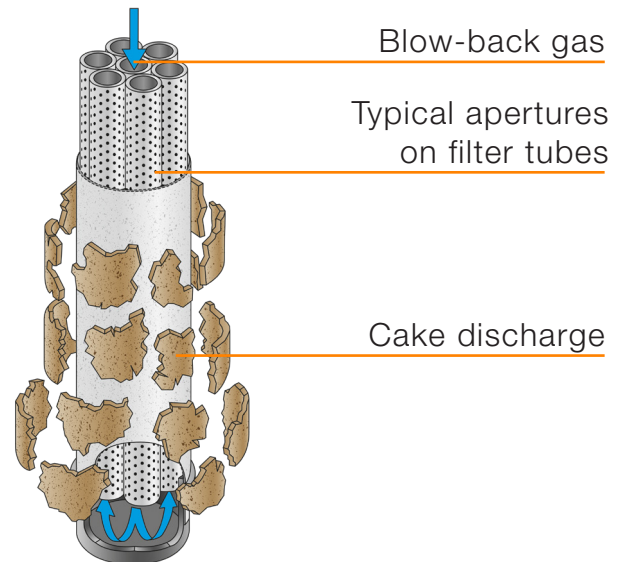

Formation and drying of the filter cake

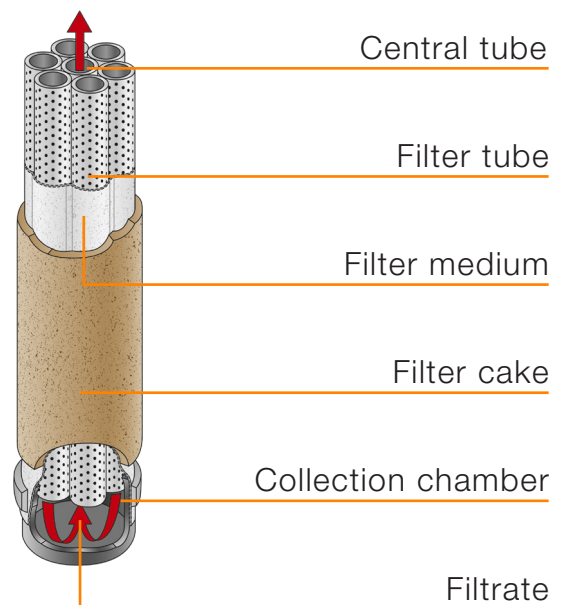

FUNDABAC[®]

Filter for dry and slurry discharge

Instrumentation nozzle

Overflow and vent nozzle

Pad flange for heel filtration spray

Register

Filtrate nozzles

Sight glass

Filter element

Filter medium
(cloth, felt,
membrane etc.)

Pressure vessel

Inspection port

Cloth clamp ring

Heel volume nozzle

Product feed nozzle

Solid residue
discharge nozzle

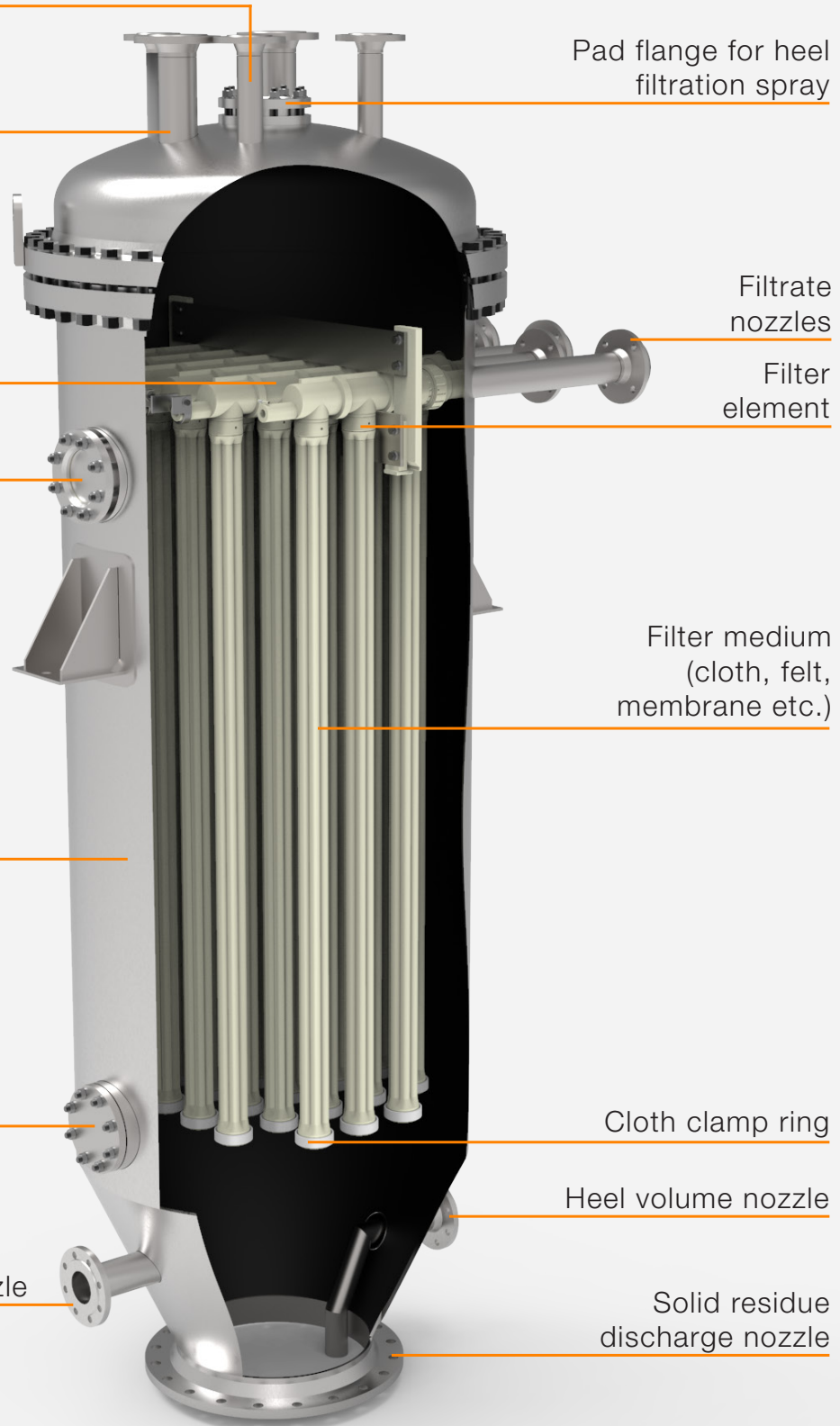

Flexible processes

Improving the effectiveness of your plant

Filtration and heel volume filtration (Pat.)

The uniform distribution of solids throughout the liquid in the filter is achieved by creating an upward flow by means of a controllable overflow. This ensures an even build-up of cake on the filter elements. If, at the end of the filtration the unfiltered heel cannot be drained to the feed vessel, heel volume filtration must be performed. This is achieved using our patented heel filtration process as follows: from the lowest point in the vessel, the heel is returned to the vessel via the feed pump and dispersed through the centrally located spray nozzle in the cover. There, the sprayed heel is evenly distributed on the filter elements and the liquid pushed through the cake by gas pressure (fig. 2).

Cake washing

At the end of the filtration step, heel filtration step, or draining of the filter by gas displacement, the cake can be washed using a suitable wash-phase. The sprayed wash-phase, using the heel filtration method, significantly reduces the volume of the wash liquid compared to conventional washing (fig. 2).

Cake drying

The washed cake is dried by blowing a suitable gas phase, e.g. ambient or hot air, nitrogen or steam through the cake on the filter elements, until the required level of residual moisture has been reached. The cake remains on the filter medium during the entire process due to the unique geometric arrangement of the tubes in the filter elements. At the end of the drying cycle the pressure vessel is vented and the discharge device opened to discharge the solids.

In-situ cleaning of the filter media

In-situ cleaning assures longer life of the filter media. Programmed according to need, the filter media are automatically washed in the closed filter to free them from possibly strongly adhering particles.

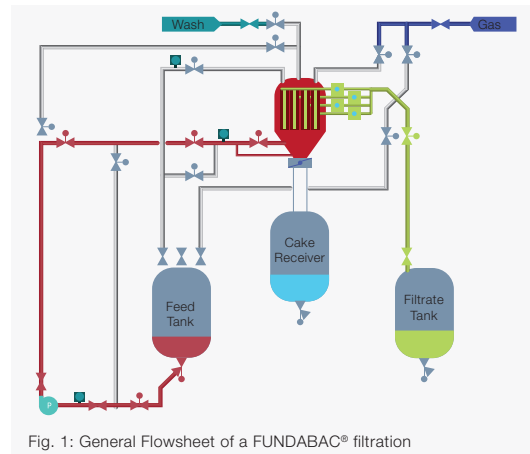

Fig. 1: General Flowsheet of a FUNDABAC® filtration

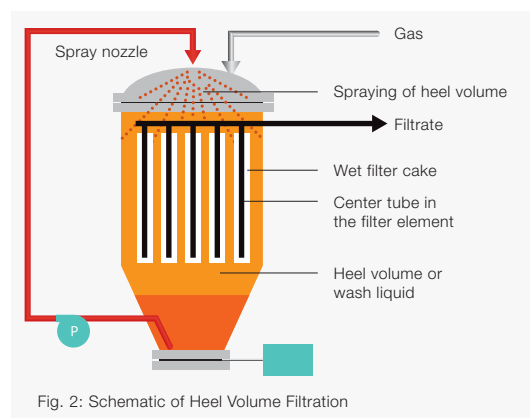

Fig. 2: Schematic of Heel Volume Filtration



Fig. 3: Filtrate outlets including sight glass for each outlet. Outlets are grouped into headers with individual pneumatically actuated valves leading into the filtrate collector.

CONTIBAC[®]

Filter for continuous thickening

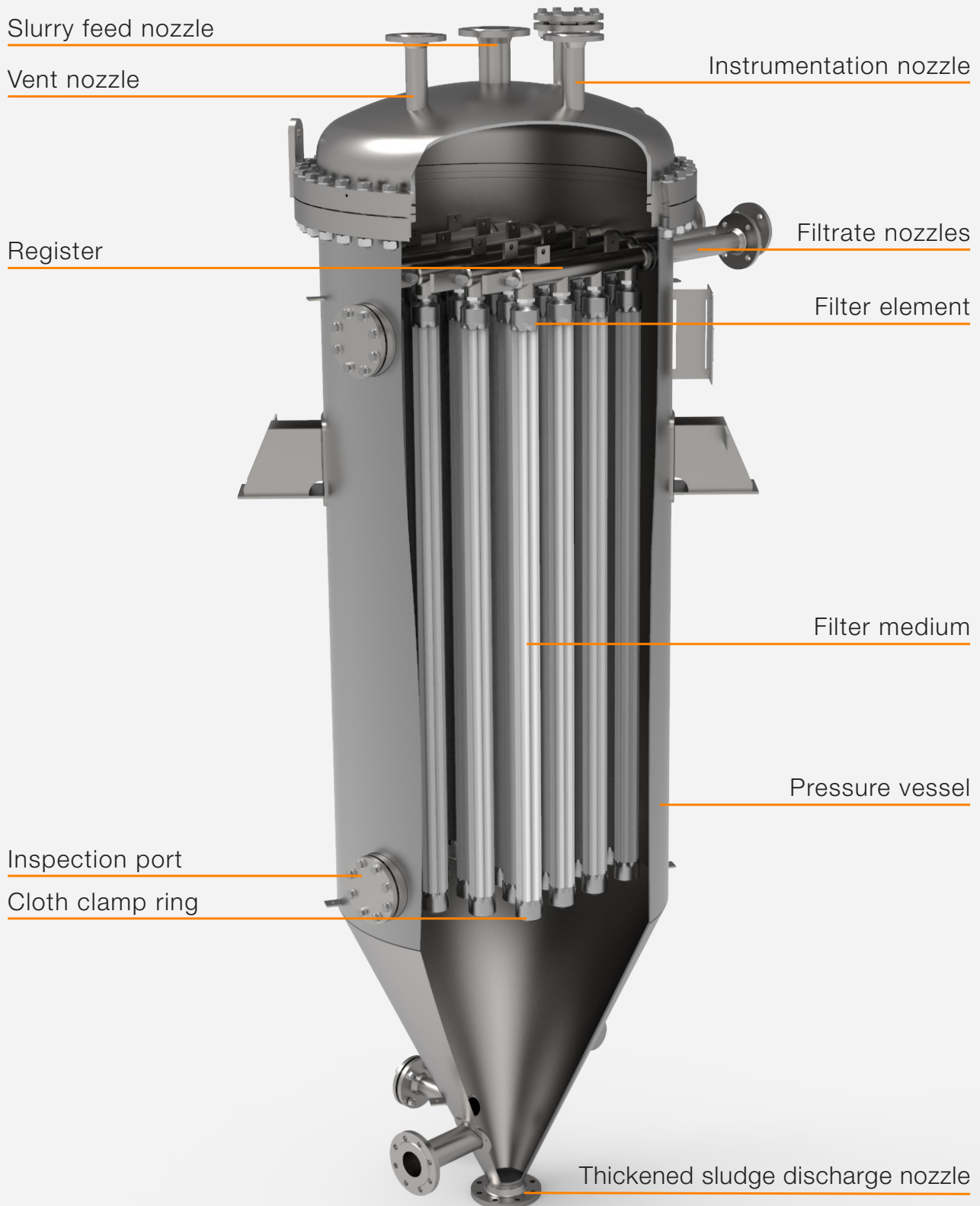

Operating modes

Continuous and semi-continuous flow

By slightly modifying the FUNDABAC® Filter, it can be operated as a continuous thickener, known as the CONTIBAC® System. In semi-continuous operation, the flow is stopped for a brief period to back-flush and discharge the solids. In continuous operation, flow is maintained by sequential back flush of the individual filtrate groups during the filtration.

Clear filtrate as well as high throughput

A clear filtrate is achieved using finely woven media, felts or membranes of fine porosity. For difficult to filter product streams, short filtration cycles build up very thin cakes, which keep the filtration rate high.

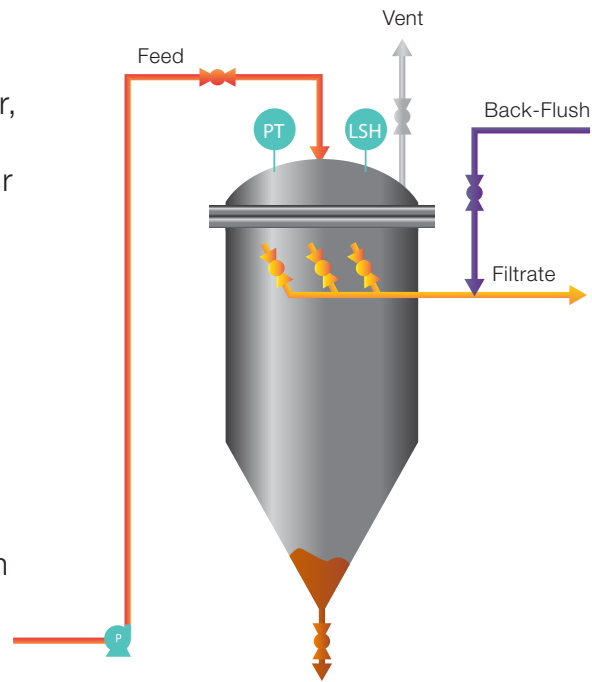

Flowsheet for CONTIBAC® operation

Filtration cycle for continuous operation

During filtration all but one filtrate group are in filtration mode, while one group of filter elements is back-flushed. The freed filter cake of this group sediments rapidly into the conical bottom of the filter from where it is discharged. Once this group has regenerated, the filtration commences followed by the next group which jumps into regeneration.

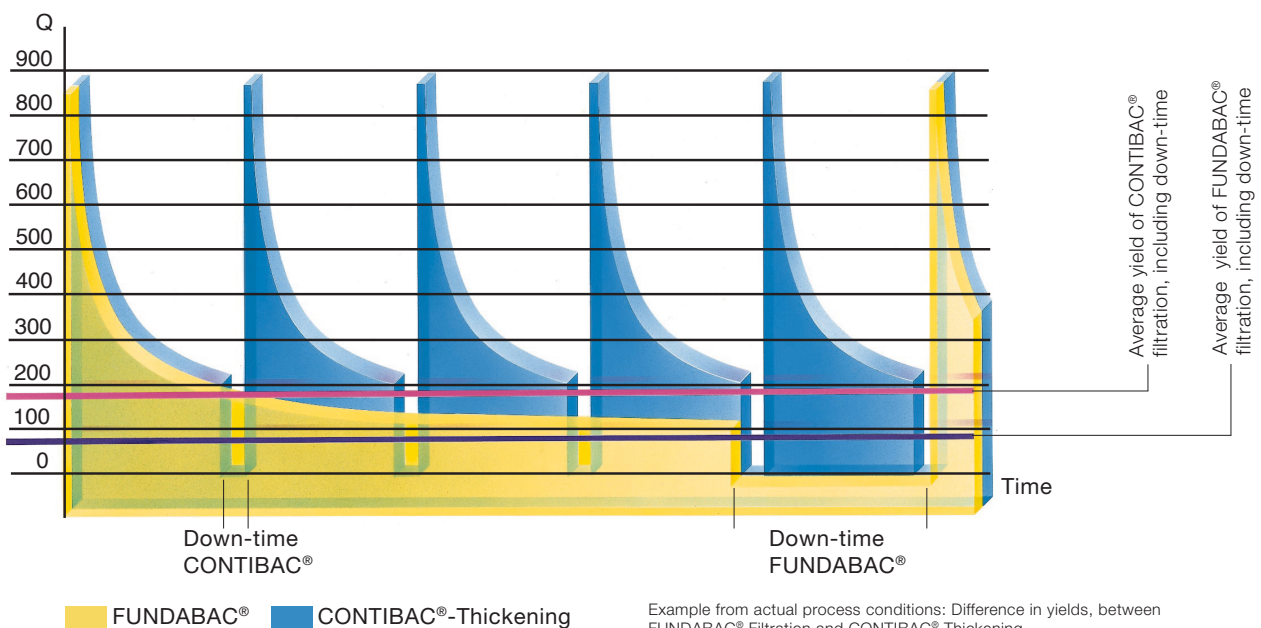

Example from actual process conditions: Difference in yields, between FUNDABAC® Filtration and CONTIBAC® Thickening

STERIBAC[®]

for Pharma and Biotech applications

The STERIBAC[®] is a filtration system specifically designed according to GMP standards for the pharma and biotech industry. It can offer important advantages as compared to other solid/liquid separation systems such as centrifuges, separators, nutschers or other filters:

- No rotating or otherwise moving parts essentially eliminate maintenance and the shedding of particulate matter and allows easy CIP.
- Automation of all the filtration steps, from filtration, through washing, down to the enclosed system for the discharge of the dried residue can easily be implemented, even after start-up of the system.
- The simple, modular construction of the filtration elements allows variation of size, volume and cake thickness in a fully contained system.
- Preassembled filtration modules (in the case of product dedicated internals) for quick product changes.
- Mobility and flexibility. Production cycles are short and batches change frequently. As a result, the equipment must adapt to the required process. Therefore, the machine can be easily transferred from one place to another.
- Low maintenance cost and low operating costs are achieved because of the absence of moving parts.



Low running costs

with the help of automated steps

CIP cleaning becomes an easy task, as neither mechanically moving parts nor agitating devices are present. It has been proven that with our applied CIP technology batch integrity can be maintained. Dry, slurry or reslurried discharge of solids can be changed from batch to batch.

The patented spray washing system has reduced the required washing liquids and therefore the running costs drastically. Heel volume treatment (patented) allows an essentially 100% recovery of products, for both solid and liquid heel and assures batch integrity.

Typical applications:

- Separation of biomass from fermenter slurries
- Separation of precipitated solids in downstream processing lines
- Activated carbon treatment of liquid product streams
- Heterogeneous catalyst separation from hydrogenation reactions
- Crystallized product filtration



Containment:

The entirely enclosed design prevents any contamination of the liquid streams and allows in-situ sterilization.



Applications and industries



Specialty and fine chemicals manufacturing

- Additives
- Adhesives
- Coatings
- Cosmetics
- Decolorization
- Dyestuffs
- Flavors & Fragrances
- Pigments
- Plasticizers
- Plasticizers
- Polymers
- Resins
- Rubber vulcanizer



Food and Agrochemicals

- Catalyst recovery
- Crop protection chemicals
- Fatty Acids
- Lactose syrup
- Sugars
- Sweeteners
- Vegetable oil

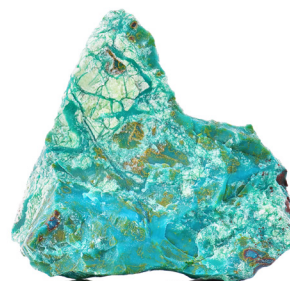

Mineral and metal processing

- Aluminum recycling
- Bauxite and Alumina filtration
- Catalyst production
- Leaching
- Lithium
- Nickel production
- Non-ferrous metals
- Potassium Nitrate
- Rare Earth
- Steel
- Titanium Dioxide
- Zeolites



Environmental

- Biodiesel impurity removal
- Carbon Capture & Storage (CCS)
- Flue Gas Desulphurization (FGD)
- Incineration waste gas treatment
- Quench water
- Recycling
- Solar cell production
- Wastewater



Bulk Chemical and Petrochemical

- Adipic Acid thickening
- Aniline recovery
- Aromatics and resins
- Butane Diol catalyst recovery
- Precious metal catalyst recovery
- Chlor Alkali
- Glycol production
- High purity epoxy production
- Removal of Hypochlorites
- Lubricant wax removal
- Olefins byproduct filtration
- Catalyst removal in oil additives
- Polyols salt removal
- Impurities removal in PPS production
- Purified Terephthalic Acid recovery
- Rubber chemicals catalyst recovery
- Synthesis Gas
- Toluene Diamine preparation and recovery



Oil and Gas Processing

- Mercury removal from crude oil
- FCC Catalyst fines
- Gas Sweetening
- MEG Regeneration
- Pigging Water treatment
- Produced Water filtration
- Sulfur recovery

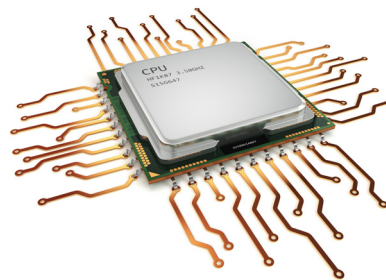

Electronics

- Copper foil production
- Graphite Oxide (GO)
- High Purity Alumina (HPA)
- LCD production
- Lithium battery production
- Lighting
- Silane
- Photoresist
- Silicon ingot and wafer slicing
- Silicon wafer shaping



Pharma and Nutraceuticals

- Active Pharmaceutical Ingredients
- Antibiotics
- Catalyst recovery
- Cell harvesting
- Decolorization
- Decolorization
- Vitamins
- X-Ray contrast agents

Extensive Know-how

in hundreds of industries

Optimization of processes significantly lowers costs. A prerequisite for this is the cooperation with a partner, such as DrM, who offers specific filtration know-how based on many years of process experience, whose laboratory technicians, chemists and process engineers can readily draw upon performance data in hundreds of applications.

The parameters of each project can be defined and quantified by the use of some 50 experimental and pilot plant FUNDABAC® available in the field world-wide. The task of optimization is achieved with the cooperation of the specialists from both partners, the client's and DrM's.

Below is a representative selection of typical processes in which the FUNDABAC® filtration system and the CONTIBAC® thickener system have proven themselves repeatedly:

- Recovery of precious metal catalysts on carbon (Pt, Pd, Rh, Ru) and Raney nickel after reaction steps.
- Removal of activated carbon used for decoloration and absorption of dissolved substances.
- Recovery of products from industrial waste streams for recycling.
- Various separation steps in the production of titanium dioxide.





- Separation of solids, such as Metal hydroxides, gypsum etc. from flue gas scrubbing plants in power stations and waste incineration plants.
- Removal of impurities in the production of ferric chloride.
- Recovery of zeolites and molecular sieve materials after belt and vacuum drum filters.
- Recovery of polymer granulates from waste streams.
- Separation of bleaching earth and activated carbon from vegetable oils.
- Cleaning of electrolytic baths in the galvanic industries (tin, zinc, nickel etc).
- Various processes in the fine chemical and pharmaceutical industries.
- Clarification of brines in the chlor-alkali industry.
- Clarification of various additives for plastics, fuels and lubricants.
- Filtration of water recycling systems in the glass and ceramic industries.



Headquarters and Subsidiaries

Switzerland Global HQ

DrM, Dr. Mueller AG
Alte Landstrasse 415
8708 Maennedorf, Switzerland

Tel. +41 44 921 2121
Fax +41 44 921 2131

mailbox@drm.ch
www.drm.ch

China

DrM Shanghai Co., Ltd.
Building 2
No. 18 Rong Xin Road
Xinqiao, Song Jiang District
Shanghai 201612, China

Tel. +86 21 5768 7390
Fax +86 21 5768 7391

Poland

DrM Polska Sp. z o.o.
Al. Kazimierza Wielkiego 5
PL87-800
Wloclawek, Poland

Tel. +48 54 237 2921
Fax +48 54 237 2931

India

DrM Filter Technology Pvt. Ltd.
Plot 46 – 1 & 2
Hansot Road Village
Pungam, Ankleshwar
Bharuch, Gujarat,
393020, India

Tel. +91 2646 652775/6

USA

DrM, Inc.
2125 Center Ave.
Suite 507
Fort Lee NJ 07024, USA

Tel. +1 201 302 0667
Fax +1 201 302 6062

Malaysia

DrM, Dr. Mueller AG
SEA Regional Office
No. 13 Jalan SE 2B
Sunway Eastwood
Taman Equine
Seri Kembangan
43300 Selangor, Malaysia

Tel. +60 3 8940 4917
Mob. +60 17 394 056

UAE

DrM, Dr. Mueller LTD
Swiss Tower, 20th Floor
P.O. Box 392394
Dubai / United Arab Emirates

Tel. +971 505710838
Tel. +971 505710839

Germany

Klaus-Günther Brekow
Waldnielerstr. 16
47839 Krefeld
Germany

Tel: +49 2151 659 19 46
Fax: +49 2151 659 19 36
Mob: +49 1752 99 8393
Email: kbrekow@drm.ch